

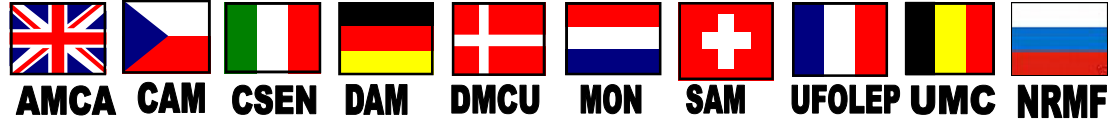

International Motor Bike Association



IMBA Secretary: Willi Jütten, Deichstrasse 6, 52525 Heinsberg - D

Internationale Motorsport Bond voor Amateurs
www.imba-mx.com

IMBA COMPETITION REGULATIONS MOTOCROSS – 2012

Verfasser / Auteur / Author:

Änderungen Kongress 2011

Stand: 01-01- 2012

Stand Versie 3

GENERAL

1. The International Motorsport Bond for Amateurs named as IMBA, acting on behalf of their European members has the right and responsibility or regulate all that is generally necessary for the motorsport.
2. European competition meetings may only be organised by affiliated members of the IMBA. Non-members can only organise after a previous and written permission of the other members.
3. The organising member is responsible for all the necessary permits and licences.
4. Members report two weeks before the next congress to the IMBA secretary their events for European, particular triple, and other international competitions. No triple on Easter, Pentecost or floodlight cross at Kleinhau/Germany.
A change of a date is permitted within 30 days after the congress.
Exception: terms may be changed during the season when a normal majority of agrees with this change 6 weeks before the term. This agreement has to be written (e-mail, fax, and letter).
Members which exceed the answering period of 2 weeks, and did not answered in writing, will have no vote. There will only be counted with yes or no votes. At an equal number of votes there is no authorisation possible, and the request will be rejected.
5. If any member is compelled to annual a meeting this must be made known to all members, at least 14 days before the date of the meeting.
 - If an event eventually has to be cancelled the day before, this will be discussed and decided whit the Organizer (sport leader from the Federation) and the present Team leaders.
 - Events that have to be cancelled two days before or on the events day, whatever the reason is, cannot once more be put on the calendar the same year, because of the costs for the federations.
 - If an event is cancelled and so the number of events is less than 5, the event can be repeated.

6. The promoting federations have to send the following forms 4 weeks in advance by email to the IMBA secretary:
 - Information sheet of the IMBA
 - The time table and Program
 - driving description and map
 - GPS dates of the raceway
 - Touristic information
 - The promoting federation has to leave tickets for the driver (two for side-car) in an envelope at the entree. Or can give there and the information on the event /race before to the team leaders
 - Team companions = 2,
 - solo drivers = 3,
 - side-car = 3, co-driver = 2,
 - Imba member 2
 - Each with tickets for the paddock.
 - The tickets are given to the drivers when they show their racing certificate at the entree this has been filled and signed by the Federation. (Federations have to give separate certificates to the driver and the co-driver.)
 - If it is no European Championship run there are other rules counting. (Look at special racing certificates.)
7. The final responsibility on matters concerning IMBA is held by the IMBA Jury, by presence in dialogue with the agent of IMBA.
 The representative of the organising country in the International Jury is responsible for:
 - call a meeting of team leaders ; (time 10:00h)
 - Make a list of riders entered, motor-marks, start numbers and names of team leaders.
 - **Where with an electronic time perception is worked, the list of the starting grid for all the 3 series is drawn up from the list of time perception.**
 - **Where no electronic time perception is used, it goes to the standing of the Championship.**
 - The starting list, results of the 3 races, day-result
 - Sending those information's to the IMBA secretary.
8. The Jury is Led by the Jury member of the organising country. The jury consists of representatives from the countries that take part in the event. Regardless of the chronometer with transponders a team of at least 3 jury members out of the team leaders is combined who are responsible for
 - a correct list of riders who participant every race
 - the manual lap scoring and riders who not finish the race
 - or rider who not did start

After the competition the team leaders undersign the final results and each team leader and the IMBA responsible receive a complete set of the days rating, lap scoring list, championship score. (The responsible sport leader of the organising country have made it and checked)

9. The prize money scheme set up in Euro is fixed annual on congress and is valid for the whole Saison. It is also binding up on AMCA, SAM, CAM, NRMF and DMCU.

10. During E.C.-meetings riders are obligated to wear their national shirts in the following colours:

Country	Tricot
Belgium	Black / yellow / red
Czech Republic	red/white/blue
Denmark	red/white
Germany	colours of national flag on a white Shirt
Great-Britain	red/white/blue
France	blue/white/red
Holland	orange
Switzerland	red with white cross
Italy	blue/white
Russia	Red blue white

Advertising slogans on shirts only permitted if agreed by IMBA-committee, there are special rules. (See section 58). If before the start a slogan does not comply to the rules, a rider will be excluded from the race. If none compliance is established after the start the rider will be disqualified.

Shirts of all countries have to have back-numbers which are silhouetted against the underground. The letter-size has to be at least 20 cm, the width proportional 10 cm and the letter width 2,5 cm

Riders who do not follow the order to wear bibs will not be entered in the rating. The nation shirt has to be above the neck- or other protectors

The reigning European Champions wear during the riders presentation a rainbow shirt. This will be distributed by IMBA with the inscription IMBA – CHAMPION, class and year. Failure to do so results in loss of extra-bonus of 35 Euro for the solo champion and 50 Euro for the sidecar champion.

The actual champion-leader has to wear a yellow shirt or bib what is offer from the IMBA official

The leader in the intermediate position in the European Championship wears the yellow shirt during the performance, if it is not the reigning champion of last year, and during the three series. This shirts are awarded by the representative IMBA official and reclaimed after the races.

Each member country will use the following numbering:

Holland	1 to 9
Great-Britain	10 to 19
Germany	20 to 29
Belgium	30 to 39
Switzerland	40 to 19
France	50 to 59
Denmark	60 to 69
Czech Republic	70 to 79

Russia	80 to 89
Italy	90 to 99

Colour of the plates have to be yellow; colour of the figures have to be black.

Advertising slogans on number plates only permitted if the Starting number in the Measurements is clearly showable.

Commercials are only allowed above the numbers, maximum size 30 mm. There is no commercial allowed at the sites or under the number on the plate.

The starting numbers have to be at least **150** mm height and **75 mm** length and the number figure **25** mm

Around the numbers there has to be a free space in yellow colour of at least **15 mm**.

There are no numbers allowed with shadows or design.

For the Quads, they need an extra plate hanged behind and under the seat of the machine what you can read from the jury bus

If before the start a slogan does not comply to the rules, a rider will be excluded from the race. If none compliance is established after the start the rider will be disqualified.

11. Until the 31. January all names of the European Championship drivers have to be announced at the IMBA secretary. Changes have to be told to the secretary directly. On Monday before the next race all federations have to announce all the drivers by email at the IMBA secretary!

PARTICIPATION

12. Riders from an IMBA country which are taking part in a European competition, need to have the nationality of the country they represent. Riders from a not IMBA country, can represent a joined country. They have the same rights and obligations as the other participants. The anthem of the country they represent will be played. A sidecar passenger may have another nationality. Only riders in possession of a national licence issued by their countries Union can enter for E.C.-meetings.

Only riders may participate who in the running season do or did not participate in qualifications, practices or competitions for EC/ Nation cup (UEM) or WC/ European race (FIM) points. **Exception, riders are allowed in the country of their nationality to take part for the points classification**

If a rider, during the year, take points in a competitions for EC/ Nation cup (UEM) or WC/European race (FIM), he loose the points of the IMBA Championship.

If he does not meet the exception, and he have to give shirts and trophies back.

A. Extra conditions are:

- a rider must pass medical examination for participation in the respectively competitions;
- minimum age is 15 years = class MX2; **Ladies** (expect in France min 16 years for a 4 stroke) ;
16 year for quad, open-class and side car = 16 year ;
sidecar passenger 14 years (for riding in Belgium 15 years)
- possess a completed and signed delegation form for check-in. Schoolboy-competitors from GB need an official AMCA entry-form.

Participation of riders originating from a country which is "not" a member of IMBA, and which wants to take part in the European championships for some meetings and this with authorisation of the IMBA board, must meet the following conditions:

- The participant subscribes to an amateur status
- Participants who do not take part or have taken part for the current season in qualifications, trainings and races for the EC/ Nation cup (UEM) or WC/ European race (FIM) **Exception, riders are allowed in the country of their own nationality to take part for the points classification.**
- Originating from a country that is not a member of IMBA
- If all participating countries have claimed their right-full riders, and it is noted that there are still start places available.
- Also the application must be presented early (4 weeks) before the meeting at the IMBA secretary office.
- An insurance for the participant (day license) must be regulated.

13. All participants receive from the organising country a dated commemoration-souvenir, including team leaders and IMBA responsible.

14. A rider can only participate in one EC-category.

15. All delegates receive from their federation the competition regulations, a prize-schedule

REGISTRATION

16. All competitors must report for entry of an EC-competition at the given place and time **until 8.00h on Sunday**, their team leader may report for them. The organizer may offer a registration on Saturday from 7 to 7.30 p.m. Their national licence and delegation form must be presented. If no licence can be presented, the rider is not allowed to start. All riders must wear their licence during training and heats. He has to present this license, even out of the competition when asked by a member of the jury.

THE CIRCUIT

17. The circuit must be inspected and approved by the national circuit controller and has to be conform with IMBA-requirements.

18. Minimal circuit length: 1500 metres (1640 yds.) and not longer than 2500 m (2735 yds.). Width: 2/3 of circuit must be 8 metres (8.75 yds.) and 1/3 between 6 and 8 metres (6.6 and 8.75 yds.).

19. The minimum width of the starting fence should be 35 metres (38 yds.). We have to place a wood or a metallic tube of 10 cm et 3 metres before the start.

When the national regulations say nothing else, at least a ribbon must show the track on both sides.

THE COMPETITION

20. Flags - their significance:

green flag	signal to start motor
yellow flag	danger/caution, reduce speed, overtaking forbidden TRY TO avoid to jump/spring if it possible
red flag	stop (only start-marshal)

blue flag	lapped riders give way to overtaken
yellow flag with 1 of X	signal for last lap
black/white chequered flag	start and finish flag
blue and red flags	exit to paddock
black board or flag with riders number	rider with this number must leave the track

20a When we show flags/black board with n° during the practice or race the rider have to stop and the int. Jury will decide as plan in the points 48a and 48b of this regulation..

The question if the flag was ignored or not, it is always the point of view of the marshal and/or the official decisive.

21. Riders may not change their bike or sidecar-passenger during the heat. Between heats this is possible, only with permission of the representative of the organising land and if the motor has passed the technical scrutinise.

22. A rider chooses his own fuel unless there are national restrictions.

23. IT IS PROHIBITED TO RIDE IN THE PADDOCK.

Also for mopeds, mini bikes and similar things. Riders may be hold responsible for the trespass of their companions.

24. Riding the track in opposite direction results in disqualification; if machine is defect it must be promptly remove from track

25. If a rider causes a false start, he has to start from the second row.

26. If a rider for any reason cannot participate, the team leader must report this to the meeting-leader.

27. Competitors have to present their machine (also possible the second machine) for scrutiny before the first training. The rider has to be dressed in a complete motocross dress,

The points to be scrutinised include:

a) the machine:

1	Loose spokes, wheels, bolts or nuts
2	Play in fork and/or or ball head
3	Operation of front- and back brakes
4	Round knobs on brake and clutch handle
5	Number plates and numbers confirm to the rules
6	Good-working tip-up foot-rests
7	Sharp protrusions
8	All sidecar grips mounted inside of chair
9	Covering discs for cast-spoke wheels and sidecar chair wheel
10	Check ignition emergency interrupter
11	Check tyres for unwarranted types, as paddle and spikes
12	It has been wished to provide all engines with a good functioning flow contact

	switch. For participation at UFOLEP France is a good functioning flow contact switch obligated.
--	---

A defective machine can be withdrawn from participation, even during a race. If that is happening by Black Flag (technical Defect) then the driver is not been disqualified. He is getting into the result in the round before the Black Flag.

b) the crossdress:

1	Helmets of an approved type and good-fitting with an mouth saver
2	Good-fitting and closed clothing
3	Long sleeve shirt
4	Approved mx boots

28. Sidecar dimensions: width minimum 85 cm but not wider than 115 cm. Measurement to be taken from middle of the back wheel to middle of chair wheel. Clearance between ground and chair minimum 17 cm.

29. Classification of cubic capacity:

1	MX 2 2 Stroke MX 2 4 Stroke	Tow stroke 95 cc to 144 cc, four strokes up to 250 cc
2	Open Class	Tow stroke 175 cc to 500 cc, four strokes up to 750 cc
3	Sidecars	350 to 1.000 cc
4	Quads	200 to 1000cc max 2 cylinders
5	Ladies	Two-stroke 85 to 500 cc, Four-stroke up to 750 cc

It is not allowed to have a tolerance, for example 125 cc = max. 125 cc. Cubic capacity according to following formula: $0,785 \times \text{bore} \times \text{bore} \times \text{stroke}$. Bore and stroke in millimetres within 100th.

30. Tolerance control procedure:

- A written complaint must be done with the Jury, together with a deposit of 250 Euro for a solo bike and 400 Euro for a sidecar. Complaining is only possible by a rider competing in the same class.
- If Jury decides that the engine has to be opened while there is still a heat to go, she will have to control the servicing and to seal the cylinder. It is not allowed to change the cylinder. It is allowed to change an entire engine. The original engine immediately must be placed to the disposal of the Jury.
- The bike will be put at the clerk of the courses disposal immediately after the end of the final heat. He can decide where, in a reasonable way, the control is going to happen. He has to be present in person. The jury has the right to be present. If a control is refused, the complaint will be considered as well-grounded.
- The opening of the engine will happen by the accused or an expert approved by all parties involved. If the complaint has no ground the deposit will go to the accused. If an infraction is stated, the deposit is returned to the complainer.
- If an infraction is stated, the accused will have a penalty inflicted on him by the Jury. This penalty is only valid in IMBA competitions.

31. can be free

32. The organising member must include two 15-minutes practice periods in the program. Participation on **the both** practice is compulsory. (time First Practice 9:30h second Practice 11:00h)

Without time perception The second training is supposed to take place with starting arrangement, where the drivers take the positions of the intermediate result of the IMBA championship.

For the first Start for practice and the first race of the season, the first ten racers of the last season take their positions from the IMBA Championship, the rest of the starters have to draw lots.

Whit electronic time perception: Both practices are compulsory. The second practice is a time practice by which is recorded the fastest time of every rider/sidecar for the starting grid of all the three series

The Start

33. Competitors are expected in the box 5 minutes before the start. One helper may assist a rider in the box. Riders arriving to late must line up after behind all the other.

The formation:

a. According the list of time practice for all three series.

b. Without electronic time perception

- **For the first heat of the season according to the final core of the prior season, (only the first ten), the others will draw lots.**
- **At all following meetings the line-up will be according to point results.**
- **After the first heat at each meeting, the line-up is according to results in previous heat. Riders not listed draw lots.**

34. Starting procedure:

- After presenting the green flag (stop-watch is started) it is allowed to start the engine. All assistants must leave the box.
- At least 5 minutes after the sign that engines could be started, riders are going to the start area. If, during this period, a bike is failing, the rider can use the remaining time, until the 5 minutes are over, to repair his bike or taken his (2e) second Approval motor with the same starting numbers and to claim the starting place he has in view. This means that when a rider is in trouble, the line-up is stopped from his position till the remaining time has gone. If the time is expired, next rider is free to choose a starting place.
- When a starting place has been chosen, it may not be changed.
(In case of changing the starting place both drivers are disqualified)
- Helpers and supporters may not stay in the starting zone.
- Riders, passengers, assistants or anybody else are not allowed to work on, or change the surface of the track in front or behind the starting gate,

35. The starting signal will be the fall of the starting fence or starting flag. If an emergency occurs and less than 2/3 of the heat time has passed, a restart will follow. If more than 2/3 of the heat time has passed the result will be calculated from the last full round. The clerk of the course decides if a race can be stopped before the scheduled time. To make possible an eventual repair, there will be 15 minutes between the end of the race and the restart.

If a race has to be stopped because of accidents of one or more drivers, these drivers (if their state of health is ok) have to start from the last position if the race is redone. In the following runs they can start at their particular position.

EUROPEAN CHAMPIONSHIP

36. Teams formation:

Each country participates with the following teams:

- **Solo's:** minimum 4, maximum 6 riders (the organising country 7 riders). Every country may form a team of 5 men. In this case the organising country is allowed to form a team of 7 men.
- The maximum number of competitors in an IMBA-race is restricted to 50 .
- **If there are less than 30 competitors, the organizing country is allowed to fill up to 30.**
- **Ladies class: every country is allowed to send 4 up to 8 competitors and the organizing country is allowed to complete the ladies class up to 15 maximum if the number of 30 is not attained.**
- If any country has national limits (insurance), so these numbers count. For example: AMCA 40, CAM 45, DAM +/- 45, MON +/- 50, UISP 40, SAM +/- 50, UFOLEP 40, DMCU 50, VMCF 45.
- **Sidecar class:** minimum 4 **maximum 7** (organising country 8) teams. Normally 28 teams are allowed. **If 6** teams are starting from each country there were 35 teams.
- In France, Italy and England only 40 participants can start.
- Federations who sent the full number of racers (at least 4) 5 , 6 or 7, to all other events, automatically are allowed to send 5 drivers to France, Italy and England if they announced them.
- Federations who sent a limited number of drivers (3 or less) to all the other events, are only allowed to send a maximum of 3 drivers to France, Italy and England.
- At events in their own country, they are only allowed to announce 3+1 drivers instead of 7. For AMCA, UISP and UFOLEP (who sends the full number of drivers to other countries) is allowed to announce 5 drivers.
- Countries who want to send a 6.solo-driver or a **5. or 7.** side-car team have to announce that 2 weeks in advance at the IMBA secretary. If that does not happen one act on the assumption of 5 drivers.
- Monday before the event the IMBA secretary can see if there are any free starting positions, and if there are, the secretary can offer it to the countries who want to come with a 6.driver then to the ones who want to come with a 5.driver and so on.
- Federations, who did not announce their drivers on Monday before the race, or racers who are showing up without being announced have to bargain for not starting because there are no free starting positions left.
- Tuesday before the event the promoting federation receives the list of starting drivers from the IMBA secretary.
- On Sunday morning, if there are any free positions after the announcement of drivers, the promoting federation is allowed to give away the free places as far as the allowed number of participants is achieved. (Maximum 7 participants of the own federation.)

37. Each meeting will consist of 3 heats, of 18 minutes, **Ladies two heats of 15 minutes + 1 lap.** Duration of time between the start of each heat must be minimum 1.45 hour. Maximum Time for riders to finish on the finish line is 5 minutes after the winner have seen the finish flag

38. Points awards are as follow:

1. 60 points	11. 33 points	21. 20 points	31. 10 points
2. 54 points	12. 31 points	22. 19 points	32. 9 points
3. 50 points	13. 29 points	23. 18 points	33. 8 points
4. 47 points	14. 27 points	24. 17 points	34. 7 points
5. 45 points	15. 26 points	25. 16 points	35. 6 points
6. 43 points	16. 25 points	26. 15 points	36. 5 points
7. 41 points	17. 24 points	27. 14 points	37. 4 points
8. 39 points	18. 23 points	28. 13 points	38. 3 points
9. 37 points	19. 22 points	29. 12 points	39. 2 points
10. 35 points	20. 21 points	30. 11 points	40. 1 point

- Points are given per heat.
- Points awarded are both for the days-meeting and the general classification.
- To score points a rider has to complete 4 fully rounds. It is not necessary that a rider who stopped, passes the finish flag. Classification is based on the amount of completed laps.
- Should a driver for one or more heats on the Race day has to be been disqualified, than the other drivers are shove up in the Day-result (see also the Champion result) on the possible Place.

39. The winner of the meeting is the rider who gained the most points. If riders end with equal points the best result in the last heat is decisive.

40. At the end of all contests the rider who gained most points is European Champion. Points of a heat which is followed by disqualification will be discounted. If end results shows equal points the number of 1st places in the heats are decisive. If still equal then the number of 2nd places and so on. If the points are still equal then the last heat is decisive. After the last meeting the first three in the final score will be honoured. If a Driver is taken out of the Championship (after it, been disqualified), than the Points are not backwards adjudged. The Championship valuation stays like it was after the taking out (out the result) from the disqualified driver.

The first 3 from the E.C score each will come forward in the national country shirt at the honouring of the champion, followed by the champion(s) who will be honoured in the IMBA champion shirt.

- MX 2 (2 stroke) and MX 2 (4 stroke) also Open (2 stroke and 4 stroke)
- Near the Total result (2 and 4 stroke together) there shall be an separate Result from the Best 2 stroke driver at the end of the Championship and becoming an Cup.
- To be considered for it, there should be at least half of the Races been driven with en 2 Stroke machine.

41. Payment to riders immediately after the meeting. For Ladies it is 50% every Race.

The first 3 receive a trophy at latest 1 hour after the last heat of the meeting.
A rider keeping away from the start gets no money.

42. If a driver (except youth-class) is absent, his federation has to pay a fine of 130, € to the promoting federation.

Federations, who send a limited number of drivers, only get the fine for that number of the other federations. F.e.: CAM = 2 drivers to the DAM/ DAM = 4 drivers to the CAM. If DAM sends 0 driver, so DAM has to pay CAM = 2 drivers and 2 drivers to the IMBA cash point.

The same works for the federation who have ask for special conditions on the congress.

Table for riders who every Country have to send: **2012**

	125 cc = MX 2	Open Class	Sidecar	Ladies
MON	4	4	4	4
AMCA	4	4	2	?
SAM	4	4	4	4
DAM	4	4	3	4
CAM	4	4	0	?
UMC	2	4	4	4
UFOLEP	2	2	0	?
DMCU	2	2	0	0
CSEN	4	?	?	?
NRMF	0	0	0	0

Exceptions are only possible after an agreement of all members.

Noise measuring for the IMBA events is possible in two ways namely the dynamic method and the static test :

43. NOISE , Measuring as dynamic (Danish) method or static method.

1. Danish method.

An official have to choice the place as, for example, just after a corner.

During the measuring, the noise must be less than 90 dB (A) in a radius of 5 meters around this point.

The micro must be at 7,50 meters with an angle of 45° of the track .

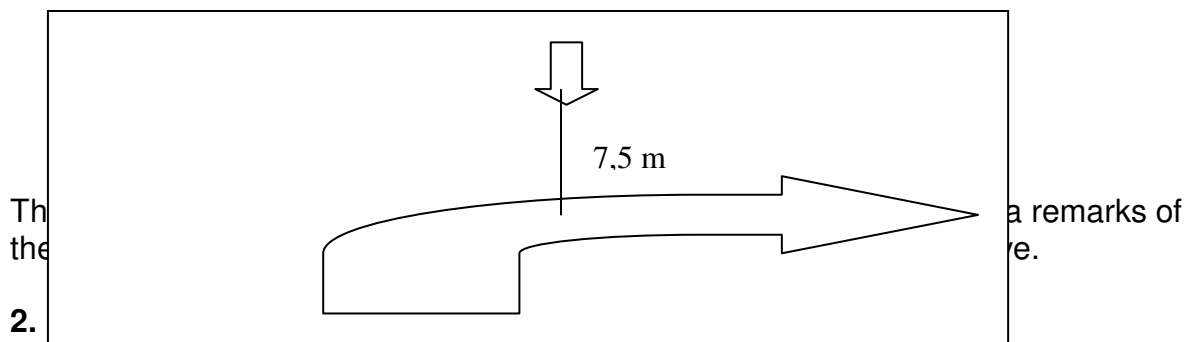

2.

The static test is called the 2 m Max method.

2.1 How to perform the 2metreMax method

Details on how to perform the 2metreMax sound control are given below.

2.2 Measuring equipment and measured parameter

- The sound level meter shall be a class 1 or class 2 instrument.
- The sound level meter shall be calibrated before and after a series of control Measure.

The slow response setting must always be used.

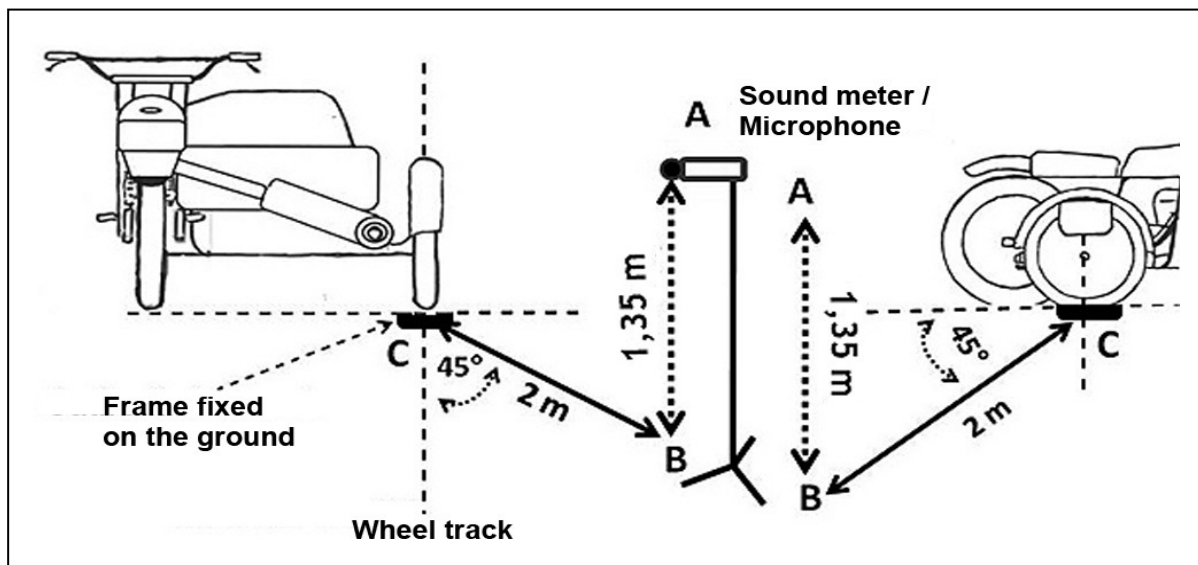
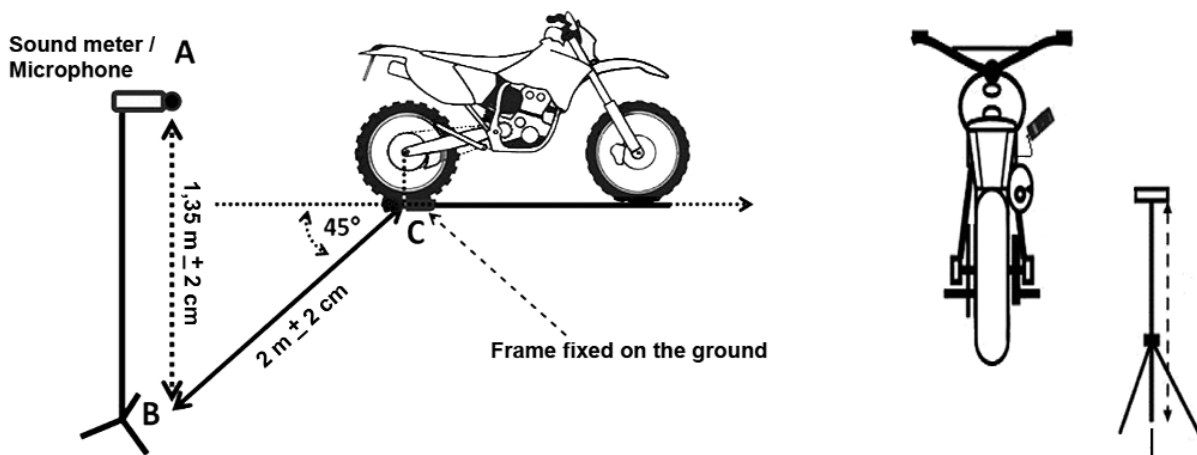

2.3. Test site

- The measurement is made behind the motorcycle at a certain angle to the side of the exhaust. If there are 2 exhaust pipes, the side with the air inlet is chosen. In case of full symmetry either side can be used.
- The motorcycle shall be held either by the rider/operator or fixed, in the upright position.
- The driver/operator shall stand beside the motorcycle, on the side of the motorcycle opposite to where the microphone is positioned.

2.4. Geometry (see picture)

- The microphone is placed at a height of 1.35 m (+/- 2 cm) directly above point A on the ground.
- Point A is situated at a distance of 2 m from point B (+/- 2cm), measured horizontally from the point where the rear wheel touches the ground. The line

from point A to point B forms an angle of 45° to the longitudinal axis of the motorcycle.

- In the horizontal plane, the microphone shall be directed at point B, where the rear wheel touches the ground. In the vertical plane, the microphone itself shall be oriented horizontally ($\pm 45^\circ$).

2.5. How to operate the engine before and during the test

- The engine and exhaust system shall be warmed up before the sound test.

- The mapping of the engine shall be the same as during practices and races.

- The motorcycle/engine shall be running in the neutral gear position.

- During the sound measurement, the engine shall be brought from idle to maximum engine speed (max RPM) by a sudden opening of the throttle (within 1 second), and back to idle by a sudden release of the throttle.

This measuring always has to take place with draw in clutch this for safety of the official. Machines tested of an event over 116.3 dBa are not allowed and the official will inform the IMBA representative.

3. Machines of riders which are tested on the day with a too high noise level first will receive from the IMBA representative a warning. If the noise level after this warning is not correct the IMBA representative informs the International Jury after which disqualification is possible for the concerning heat.

Silencers :

- A silencer or other systems have to be fixed on the silencer (on regards of the race director).

- Other systems (not fixed) are not allowed.

BEHAVIOUR

44. Purposely obstructing or fighting is penalised by disqualification.

45. A rider can be held responsible for the behaviour of his supporters. If supporters are seen on a forbidden place, the start number of the rider will be mentioned to the jury. The rider shall receive a warning. If this rule is disobeyed once more, and the report is found correct, the Jury can decide to give the rider a penalty. The scored points can be subtracted.

46. Riders must respect the regulations of the organising country if not contradictory to IMBA-regulations. If that is the case, then the Guest country has to give a copy to all the team leaders before the race (in English).

47. It is forbidden to let run to waste oil, petrol or other harmful materials into the ground, to rinse bikes with chemical waste, to dig holes in the ground for placement of caravans or busses or to dispose of parts in waste.

48. Complaints should be lodged in writing to the representative of the organising union in the International jury. At least 15 Minutes after the Race, or after the hanging of the Result at the Jurybus. This must be done by a rider or by his team leader if the complaint is signed by the rider. A complaint about an exceeded cubic capacity has to be made by the rider himself.

PENALIZATION

49. The jury can decide to give penalties as:

- Official warning.
- Loosing of 5 place in the result of the race if there was **no risk** for other riders, person,...
- Disqualification in the result of the race if there was **risk** for other riders, person,...
- Suspended suspension.
- Effective suspension.
- Interdiction to the start.
- Disqualification of a heat, meeting or championship raking.
- Suspension for a limited or unlimited period.
- Withholding of the expense money.

A penalty will be given to a rider in writing and can be imposed by the Jury or the IMBA-committee. If done by the jury the IMBA Sports leader should be informed within 48 hours.

50. Given penalties are only valid at IMBA-ruled events.

51. A rider can only appeal in writing to the IMBA-committee, at least within 2 weeks after the decision was send by IMBA.

If an appeal is made, the committee will try to deal with it within 14 days. The final IMBA decision has to be accepted,

There is no appeal possible.

An appeal is getting/can be/is discussed on a place determined by IMBA.

The rider who made the appeal has the right to be present.

If a quicker treatment is wished (race schedule), IMBA can discuss the case by alternative ways of communication. If it is impossible to be present for the rider who made the appeal, he may clear up his case in any way.

Should be further information and explain be necessary, than the Board shall give the Concerned given the possibility to lay it down.

FINAL CONDITIONS

52. Participating riders in IMBA-contests must be familiar with these regulations. They agree not to involve other courts out of IMBA and agree to accept IMBA decisions.

53. When a selected EC-rider leaves his national federation he automatically loses all rights.

54. The IMBA regulations and the supplementary Youth-regulations are in force during the organisation of International Youth-meetings.

55. The meeting-leader decides on matters not contained in these regulations, in consultation with the IMBA-delegate if present. Decisions made by the IMBA-delegate will be carried out regardless of appellation.

56. Advertising is allowed on the shirts and jackets of the riders in meetings for the European Championship, according to the sponsorship rules.

SPONSORSHIP RULES

1. Race shirts may contain publicity during the race: the total area of the logo's on chest – and back-side may not exceed 300 square centimetre. Each sleeve may show 3 publicity logo's of 40 square centimetre each. The area is determined by tracing the smallest possible rectangle around the logo.

2. If a jack is worn during presentation, it may show 3 logo's: left chest, right upper arm, left upper arm or collar.
3. Shirt publicity is for the whole team, not individual. More sponsors for one team are permitted.
4. Before wearing the logo's they have to be presented to the IMBA-committee. They are subject of a written permission. An example of the showed logo's is kept by IMBA to check for similarity. The unions are fully responsible for carrying out the advertising regulations.
5. The publicity is checked by the team leaders. If any different is found, this will be reported to the president of sports. The report must be signed by two team leaders.
6. By in case of any contravention the right for prize-money en EC-points is lost.

Made at Heinsberg, January 2012

Star point with correct starting number

